



DESCRIPTION

Flair is the low profile contemporary looking ceiling mounted, high performance header box fan that has been designed to clear rooms of steam and reduce the build-up of unpleasant odours. It features a high performance centrifugal impeller that produces powerful air flow and low noise. It is suitable for 150mm diameter duct size connection.

Typical Applications

Exhaust from residential or light commercial applications such as toilets, bathrooms laundries, kitchens and ensuites. Its compact height and side exhaust outlet makes it suitable for confined spaces such as cathedral ceilings and between floors.

Features

- Modern contemporary looking design.
- Fitted with a non-return backdraft damper.
- Removable clip-in grille makes cleaning easy.
- Convenient installation with ceiling latch or screw-in fixing.
- Designed for use in ducted systems.
- Made from durable injection moulded plastic.
- Includes plug and lead which helps to make installation easier.

Construction

Housing and grille are made from injected moulded plastic. Fans are forward-curved centrifugal, driven by squirrel cage motor.

Motor

Type - squirrel cage induction motor.

Electricity supply - 230V, single-phase, 50Hz.

Bearings - sealed for life, ball.

See pages O-2/3 for details on these motors.

Internal Thermal Protection

Manual-reset thermal protection is fitted as standard

Testing

Air flow to ISO5801: 2007

Noise to ISO3744: 2010

SUGGESTED SPECIFICATION

The ceiling fans shall be of the Flair Header Box Series as designed by Fantech Pty Ltd and be of the model number shown on the schedule/drawing.

Impellers shall be forward-curved centrifugal and driven by a squirrel cage motor with integral thermal protection. Fans shall be fitted with a non-return backdraft damper and removable clip-in grille.

They shall be tested to ISO5801: 2007 for air flow and ISO3744, 2010 for noise.

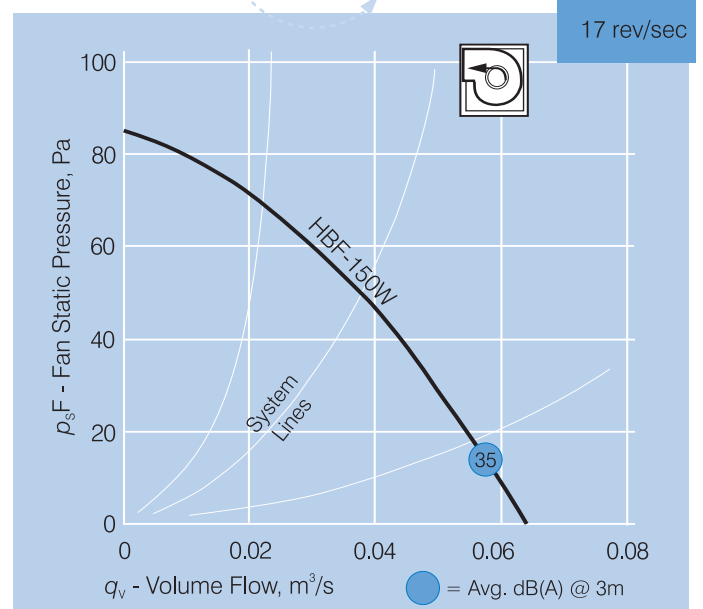

TECHNICAL DATA

Model Number	Fan Speed rev/sec	Avg. dB(A) @ 3m	Watts	Amps	App. Wt. kg
HBF-150W	17	35	35	0.15	3.25

DIMENSIONS

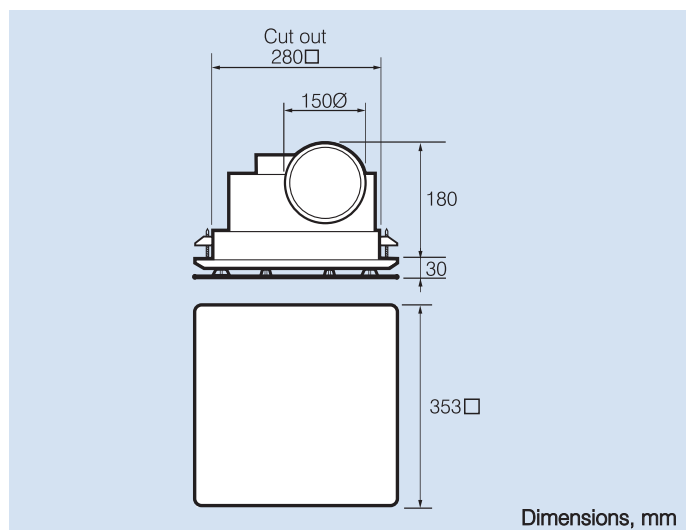

ANCILLARY EQUIPMENT

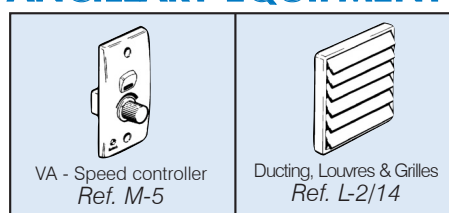

Scan the QR Code to view more information online.

