

COMPACT FLAMEPROOF MINIDUCT SERIES

B

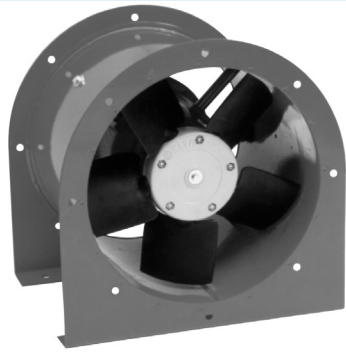

DESCRIPTION

The Compact Series of Flameproof Miniduct fans has been specifically designed for duct mounting and to ventilate hazardous or explosive environments.

There are 4 sizes in the range extending from 250 to 400mm diameter.

Typical Applications

Fantech's Compact Flameproof fans can be used to exhaust in areas where the environment has been defined as being hazardous or explosive necessitating the use of flameproof motors. These areas include spray booths and battery charge rooms. They are suitable for all Group II hazardous gas environments **EXCEPT** for the following:

- Where the ambient temperature is less than -20°C or greater than 40°C.
- Where the fan is exhausting from the vapour space of a tank or vessel (Zone 0). See Page O-5/7 for details on Zones)
- Where the fan is exhausting immediately adjacent to a continuous source of release (Zone 0).
- In mines susceptible to fire damp.
- Where special conditions exist such as corrosion, water, dust, vibration or high level of UV exist.

Features

- Galvanised steel casing with red powder-coated finish.
- Anti-static blades.
- Suitable for ducted installations.
- Can be mounted at any angle.
- Designed for single-phase supply.
- Motors comply with Ex d, Group II, Zone 1, T6 protection - see **Special Note**.
- IP66 rated.

Construction

Galvanised steel casing with red powder-coated finish. Axial impellers have glass reinforced anti-static blades.

Motors

Type - squirrel cage induction motor.

Electricity Supply - 230V, single-phase, 50Hz.

Bearings - sealed-for-life, ball

Maximum ambient temperature 40°C.

These motors are not speed-controllable.

See pages O-5/7 for details on these motors.

Internal Thermal Protection

The motor is fitted with thermal protection to conform to the requirements of AS1359. IECEx certification and classification of T6 does not take into account abnormal operation such as locked rotor where the temperature of the surfaces may exceed 85°C. If this is an issue with your application, further protection should be fitted.

Testing

Air flow tests to ISO5801:1997, 'Type 'D' Installation (ducted inlet and outlet).

Noise tests to BS848:Part 2, 1985.

Wiring Diagram

See page N-8, diagram ER6.

Special note

These products have a Certificate of Conformity issued under the IEC Ex Certification Scheme for Explosion Protected Electrical Equipment.

This certificate, number IEC Ex TSA 14.0024X, covers these fans for Ex d GroupII, Zone 1 protection. These fans are approved for gas Groups IIA, IIB and IIC, have temperature classification T6 and enclosure protection IP66.

ANCILLARY EQUIPMENT

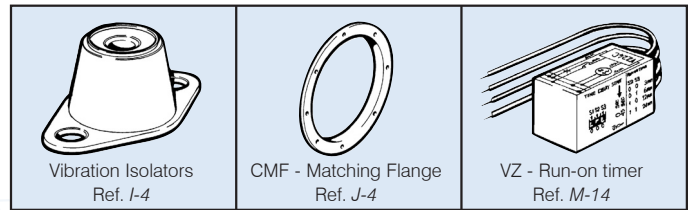

TECHNICAL DATA

Model FPMD...	Fan Speed rev/sec	Avg dB(A) @ 3m	FPMD.. 1 ph. Watts Amps	Approx. wt. kg
254	23	45	120 1	13
304	23	48	120 1	15
354	23	50	120 1	16
404	23	52	120 1	18

SUGGESTED SPECIFICATION

The fans shall be of the Compact Flameproof Miniduct Series, as designed and manufactured by Fantech Pty Ltd and shall be of the model numbers shown on the schedule/drawings.

They shall be approved for gas Groups IIA, IIB and IIC, have temperature classification T6 and enclosure protection IP66.

They shall have a galvanised steel casing with a red powder-coated finish and be fitted with glass reinforced anti-static blades.

All data shall be based on tests to ISO5801:1997, Type 'D' Installation for air flow and to BS848:Part 2, 1985 for noise.

HOW TO ORDER

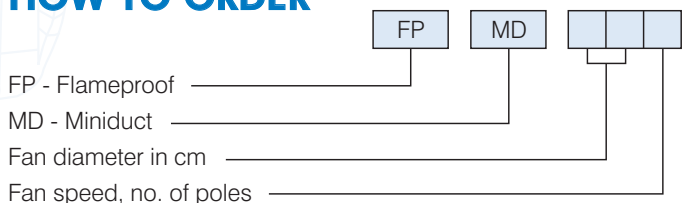

COMPACT FLAMEPROOF MINIDUCT SERIES

NOISE DATA

Model FPMD...	Inlet	In-duct Sound Power Levels L_w dB re 1pW							
		63	125	250	500	1k	2k	4k	8k
254	Inlet	66	72	70	63	57	54	57	38
304	Inlet	66	78	68	67	61	58	54	48
354	Inlet	67	80	71	66	62	61	57	51
404	Inlet	72	72	68	66	69	67	63	50

Sound Power Levels at 50% of peak pressure and on the Inlet Side of the unit.

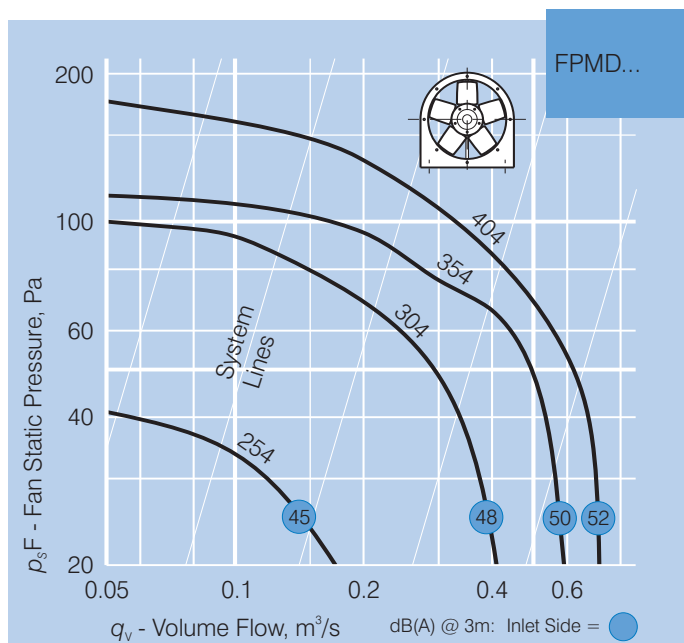

DIMENSIONS

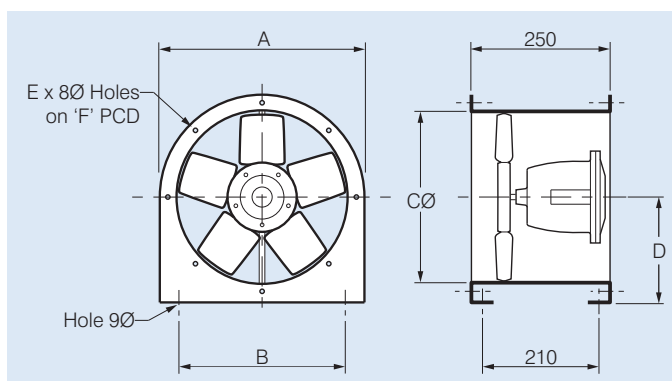

Model FPMD...	Dimensions, mm					
	A	B	CØ	D	E	F
254	318	250	260	160	8	285
304	368	300	310	190	8	340
354	420	350	360	220	8	395
404	470	400	410	250	12	438



Scan the QR Code to view more information online.

