

# FLANGED VERTICAL DISCHARGE COWLS

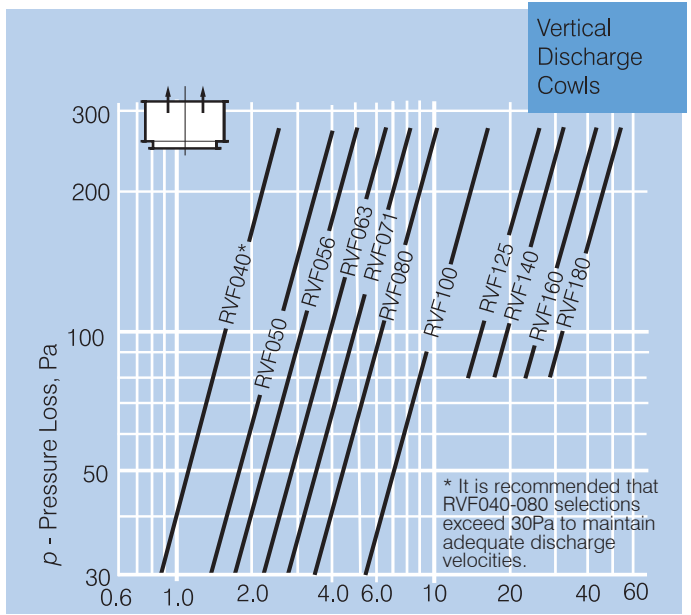

## DESCRIPTION

The Flanged Vertical Discharge Cowls are ideal in ducted systems where the fan is mounted remotely below roof level. They work together with a mechanical exhaust system while preventing the entry of rain when not in use. These durable and robust units are designed for mounting on circular duct and flue discharges using a flange.

There are 11 sizes in the range handling air flows from 0.2 to 55 m<sup>3</sup>/s.

## Typical Applications

Used as the discharge point where the fan is mounted elsewhere in the system yet vertical discharge exhaust is required. Ideal in applications such as shopping centres, office buildings and sports centres. The pressure loss through the cowl must be added to the system pressure loss before selecting the fan.

## Features

- Enables the vertical discharge of air while preventing rain from entering building.
- Steel components have a corrosion resistant finish.
- Fitted with reliable gravity air-operated backdraft shutters.

## Construction

Backdraft shutters: Sizes 40 to 80 - Made from aluminium.  
 Sizes 100 & 180 - Made from galvanised sheet steel.

Cowls are of galvanised steel.  
 Fitted with gravity air-operated backdraft shutters.  
 Steel components have a corrosion resistant finish.

## Special Notes

Flanged Vertical Discharge Cowls are designed for relatively high air discharge velocity. At low discharge velocities, rain could enter the building. For these types of applications an Alpha Relief Air Vent is recommended. See page D-10.

For any application where prevailing winds may lift the shutters of the Flanged Vertical Discharge Cowl, we recommend the fitting of Magloks®. See page J-8 for details.

Ensure the hinge of the shutter points down the slope of the roof.

## SUGGESTED SPECIFICATION

The vertical discharge cowls shall be of the RVF series as designed and manufactured by Fantech Pty Ltd. Each unit shall incorporate gravity air-operated backdraft shutters that are constructed from aluminium or galvanised sheet steel.

Cowls are of galvanised steel and steel components shall have a corrosion resistant finish.

## HOW TO ORDER

Select the model required to handle the air quantity nominated from the performance graphs.

## DIMENSIONS

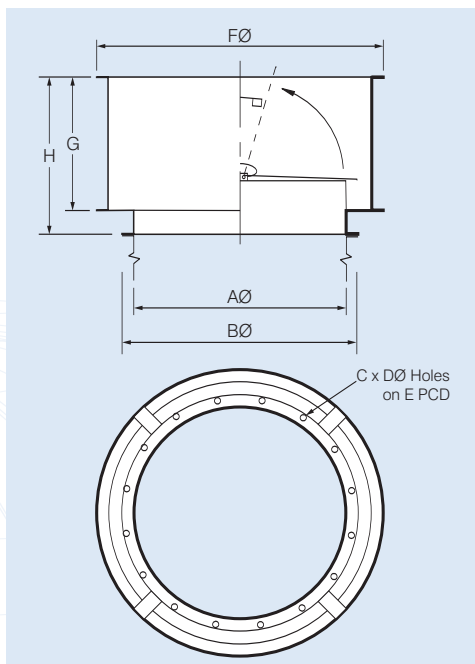

Scan the QR Code to view more information online.

Model RVF..	Dimensions, mm								App. wt. kg	App. vol. m <sup>3</sup>
	AØ*	BØ	C	DØ	E	FØ	G	H		
040	400	485	8	12	450	656	300	380	19	0.12
050	500	585	12	12	560	756	350	430	25	0.19
056	560	645	12	12	620	816	380	460	28	0.24
063	630	715	12	12	690	886	400	480	32	0.29
071	710	795	16	12	770	966	450	530	37	0.39
080	800	885	16	12	860	1056	500	580	44	0.51
100	1000	1106	16	15	1070	1258	600	680	61	0.85
125	1250	1356	20	15	1320	1508	700	780	85	1.38
140	1400	1526	20	15	1470	1658	800	880	117	1.90
160	1600	1730	24	19	1680	1854	900	980	157	2.64
180	1800	1960	24	19	1880	2053	1000	1080	195	3.57

\* Nominal Duct Diameter