

Fantech Jetstream System

Ø200mm Spigot



CONTENTS & INSTALLATION INSTRUCTIONS

Contents:

Jetstream Fan	1 off.
Mounting Bracket	1 off.
Fixing screws	4 off.
Installation Instruction	1 off.

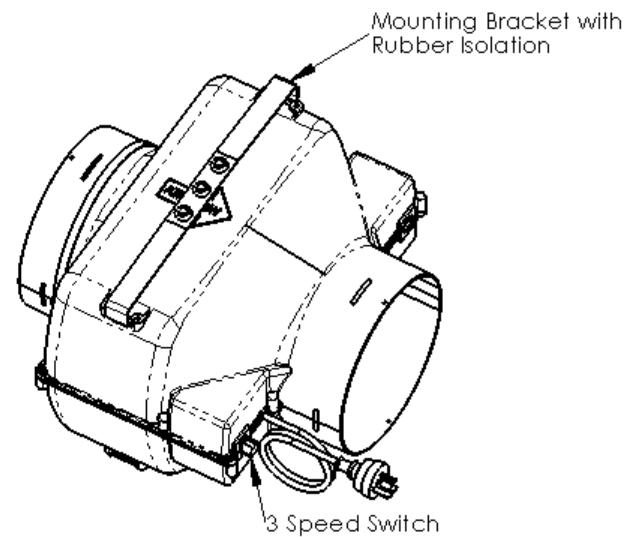
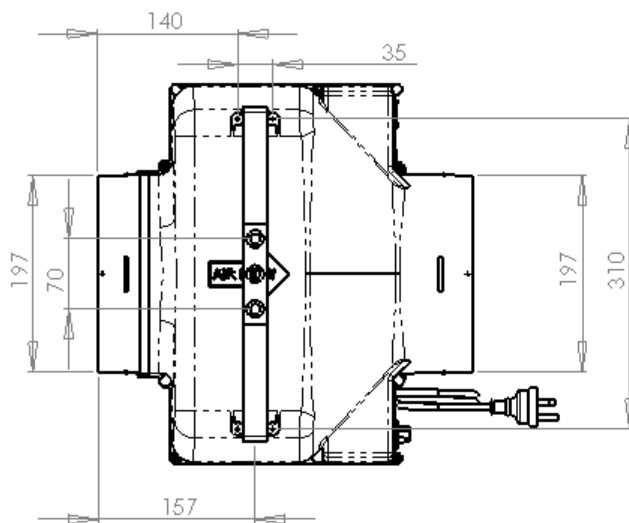
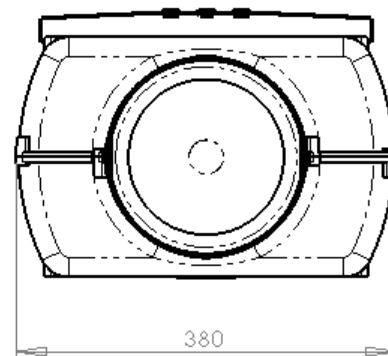
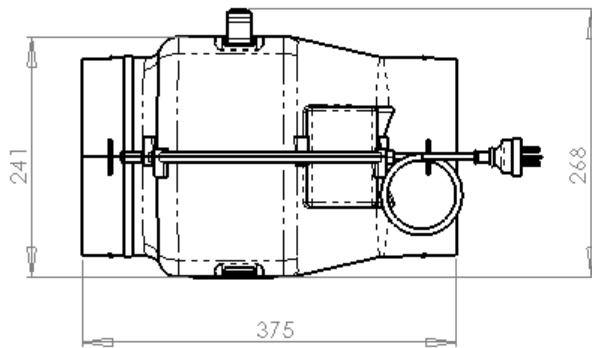

Installation:

1. Installation of this product should be carried out by appropriately qualified persons.
2. Ensure the unit has arrived in good condition and that the impeller is free to rotate.
3. The Jetstream Fan can be installed in one of two ways:

A). Fix the mounting bracket where the fan will be installed and snap the fan into the bracket.

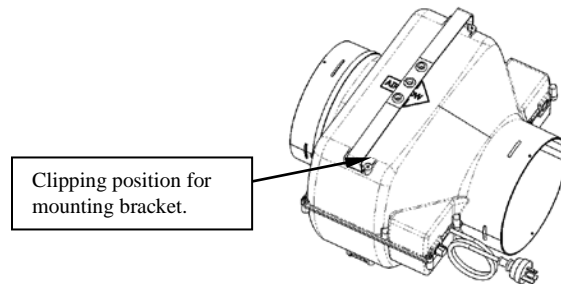

B). Utilise the four holes and four screws provided to fix the fan appropriately.

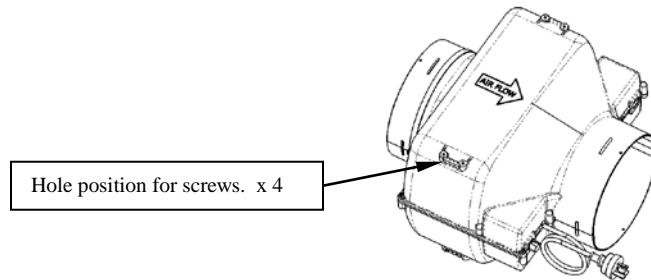

4. Plug fan into 240V AC power point.

Safety Considerations:

1. All connections must be in accordance with any local regulations.
2. Changing the pre-set speed or connection to a remote three speed switch must be done by a qualified person.
3. The Licensed Electrical installer must ensure that an approved means of disconnection be incorporated into the fixed wiring.
4. This fan has an automatic thermal cut-out switch incorporated in the motor as standard.
5. This product is not intended for use by persons (including children) with reduced sensory or mental capabilities, or lack of experience and knowledge, unless they have been given supervision or instruction concerning use of the product by a person responsible for their safety. Children should be supervised to ensure that they do not play with the product.
6. For duct or partition mount, precautions must be taken to avoid the back-flow of gases into the room from the open flue of gas or other open-fire appliances.
7. If the supply cord is damaged it must be replaced by the manufacturer, its service agent or similarly qualified persons in order to avoid a hazard.

GOODS AND WARRANTY

1. When supplying goods to a consumer, the following mandated statement applies:
"Our goods come with guarantees that cannot be excluded under the Australian Consumer Law. You are entitled to a replacement or refund for a major failure and for compensation for any other reasonably foreseeable loss or damage. You are also entitled to have the goods repaired or replaced if the goods fail to be of acceptable quality and the failure does not amount to a major failure."
2. The benefits of this warranty are in addition to any rights and remedies imposed by Australian State and Federal legislation that cannot be excluded. Nothing in this warranty is to be interpreted as excluding, restricting or modifying any State or Federal legislation applicable to the supply of goods and services which cannot be excluded, restricted or modified.
3. Subject to the conditions and limitation below, the Company warrants products of its manufacture to be free of defects in workmanship and/or materials at the time of delivery to the Buyer.
4. Any part, assembly or portion thereof found to be defective within one year from the date of commissioning or eighteen (18) months from date of shipment from our factory, whichever is the sooner, unless expressly stated otherwise in the Company's Publications or Literature, will be repaired or exchanged F.O.B factory.
5. The Company reserves the right to replace defective parts of the goods with parts and components of similar quality, grade and composition where an identical component is not available.
6. Goods presented for repair may be replaced by refurbished goods of the same type rather than being repaired. Refurbished parts may be used to repair the goods.
7. Goods or parts that have been returned for repair (except where the repair is as a result of the Company's failure to comply with the statutory guarantees in the ACL) or warranty assessment are deemed to have been abandoned by the Buyer if not collected within 30 days after the Company has notified the Buyer in writing of the warranty assessment outcome or the completed repair.
8. The Company reserves the right to dispose or otherwise deal with an abandoned product or part at its discretion.
9. This warranty does not apply if:
 - (i) the goods have not been paid for by the Buyer as per the credit terms provided; or
 - (ii) the goods have not been installed in accordance with AS NZS 3000/2000 Australian/New Zealand Wiring rules; or
 - (iii) the goods have been misused or neglected.
10. The Company assumes no responsibility under this warranty for the labour costs involved in the removal of defective parts, installation of new parts or service charges related thereto.
11. If a fault covered by this warranty occurs, the Buyer must first contact the Company at the contact address listed below.
12. Any warranty claim must be accompanied by:
 - (i) proof of purchase;
 - (ii) written details of the alleged defect; and
 - (iii) appropriate documentation (such as installation and maintenance records etc).
13. The Company shall have the option of requiring the return of the defective part (transportation prepaid by the Buyer) to establish the claim.
14. The Company makes no warranties or representations other than set out in this clause 7.
15. The repair or exchange of the goods or part of the goods, is the absolute limit of the Company's liability under this express warranty.



FANTECH
Intelligent Ventilation

Fantech Contacts

<p>Head Office Victoria - Melbourne A.B.N. 11 005 434 024 Ph: +61 (3) 9554 7845 Fax: +61 (3) 9554 7833 Email: info@fantech.com.au</p>	<p>New Zealand Auckland H.O. (09) 444 6266 Christchurch (03) 379 8622 Wellington (04) 566 0532</p>	<p>Asia For agents in the Asian region call (603) 7846 0340 or visit www.eltafantechasia.com</p>
<p>Australia Adelaide (08) 8294 0530 Brisbane (07) 3299 9888 Darwin (08) 8947 0447 Melbourne H.O. (03) 9554 7845 Perth (08) 9209 4999 Sydney (02) 8811 0400</p>	<p>www.fantech.com.au</p>	