

Compact Cooler Standard



CONTENTS & INSTALLATION INSTRUCTIONS

Contents:

<u>Description</u>	<u>Part No.</u>	<u>Quantity</u>
Axial fan	SCE0564	1 off.
Bracket	BRKT-F	3 off.
Installation Instruction	INSTCCS	1 off.
Wheel Assembly.		
Wheel & hubcap	COM-WHEEL125	2 off.
Bolt 12mm x 70mm long	BOL12-70	2 off.
Washer 12mm flat	WAS12.0	6 off.
Washer 12mm spring	WAS12.0SP	2 off.
Nut 12mm hex	NUT12	4 off.
Handle Assembly.		
Handle	HANDLECCS	1 off.
Bolt M12x25 long	BOL12-25	1 off.
Washer M12 flat	WAS12.0	1 off.
Washer M12 spring	WAS12.0SP	1 off.
Final Assembly.		
Bolt M10x20 long	BOL10-20	12 off.
Nut M10	NUT10	12 off.
Washer flat M10	WAS10.0	12 off.
Washer spring M10	WAS10.0SP	12 off.
Grommet	GROM-MUSH	2 off.

Inspection:

Ensure the unit has arrived in good condition and that all items are free of damage

Assembly:

Remove all the components from the carton.

Assemble the 'wheel assembly' and 'handle assembly' and bolt them and the other bracket to the fan as detailed below.

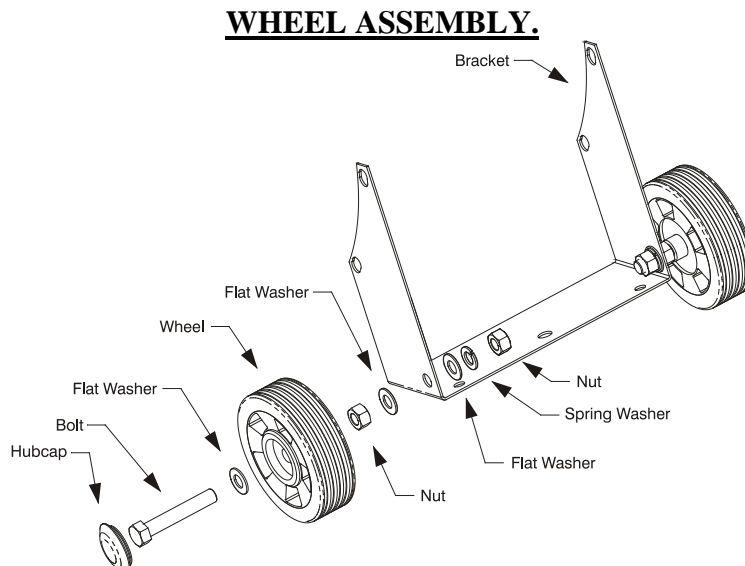

Remove the 'wheel assembly' components from the bag and assemble the 2 wheels to one of the brackets as shown above.

HANDLE ASSEMBLY.

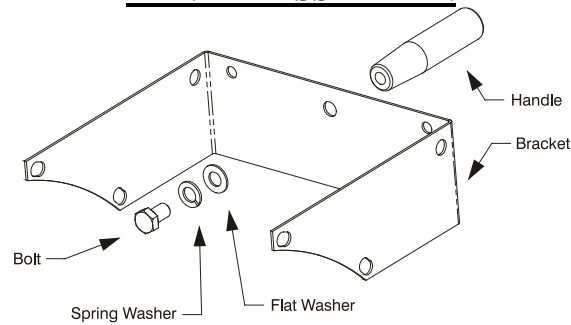

Remove the 'handle assembly' components from the bag and assemble the handle to one of the brackets as shown above.

FINAL ASSEMBLY.

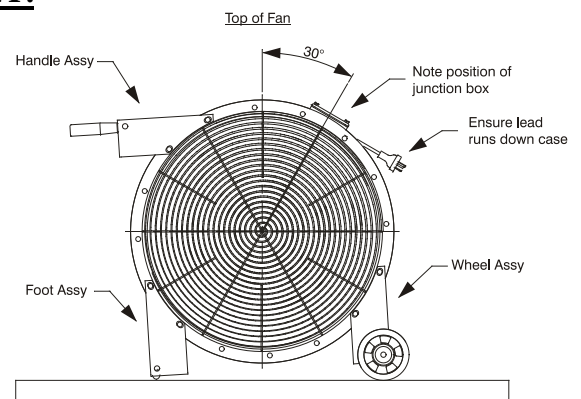
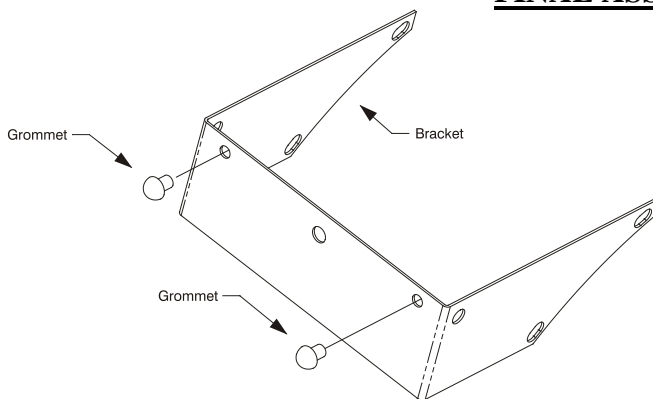

1. Remove the final assembly components from the bag.
2. Insert 2 off grommets into the holes in the other bracket as shown above. (Twisting whilst pushing will aid fitment)
3. Place fan on a flat surface, guard down in the orientation as shown above.
4. **Note the orientation of the junction box and ensure the lead exit from the junction box is facing down.**
5. Position the bracket assemblies as shown above and assemble to case.

Safety Instructions

READ THESE INSTRUCTIONS CAREFULLY BEFORE USING THE PRODUCT, KEEP THEM HANDY FOR FUTURE REFERENCE.

1. Always operate the Fan from a power source of the same Voltage, Frequency and Rating as indicated on the Product Label.
2. This Fan must only be plugged into an approved socket, which is earthed in accordance with the Local Electrical Supply Regulations.
3. The Fan must be assembled as per instructions.
4. This fan has a replaceable in-line fuse for motor protection. If fuse continually blows, switch the fan off immediately and return the complete unit to the manufacturer or service agent, for repair.
5. Always switch off and unplug the Fan from the supply when maintenance or cleaning is to be carried out.
6. Do not operate the Fan with either guard removed.
7. Do not move the Fan by pulling the supply cable.
8. Do not operate the Fan with a damaged Cord or Plug, or after the product malfunctions, or is dropped, or appears damaged in any manner. Return the complete Fan immediately to the manufacturer or service agent, for repair.
9. When cleaning, Do Not hose or apply high pressure water to the motor or electrics, simply wipe down with a moist cloth or brush.
10. Always operate the Fan on a dry, level surface.
11. This product is not intended for use by young children or infirm persons without supervision.

Failure to follow the above safety instructions could result in abnormal operation, fire, electric shock or injury.

GOODS AND WARRANTY

1. When supplying goods to a consumer, the following mandated statement applies:
"Our goods come with guarantees that cannot be excluded under the Australian Consumer Law. You are entitled to a replacement or refund for a major failure and for compensation for any other reasonably foreseeable loss or damage. You are also entitled to have the goods repaired or replaced if the goods fail to be of acceptable quality and the failure does not amount to a major failure."
2. The benefits of this warranty are in addition to any rights and remedies imposed by Australian State and Federal legislation that cannot be excluded. Nothing in this warranty is to be interpreted as excluding, restricting or modifying any State or Federal legislation applicable to the supply of goods and services which cannot be excluded, restricted or modified.
3. Subject to the conditions and limitation below, the Company warrants products of its manufacture to be free of defects in workmanship and/or materials at the time of delivery to the Buyer.
4. Any part, assembly or portion thereof found to be defective within one year from the date of commissioning or eighteen (18) months from date of shipment from our factory, whichever is the sooner, unless expressly stated otherwise in the Company's Publications or Literature, will be repaired or exchanged F.O.B factory.
5. The Company reserves the right to replace defective parts of the goods with parts and components of similar quality, grade and composition where an identical component is not available.
6. Goods presented for repair may be replaced by refurbished goods of the same type rather than being repaired. Refurbished parts may be used to repair the goods.
7. Goods or parts that have been returned for repair (except where the repair is as a result of the Company's failure to comply with the statutory guarantees in the ACL) or warranty assessment are deemed to have been abandoned by the Buyer if not collected within 30 days after the Company has notified the Buyer in writing of the warranty assessment outcome or the completed repair.
8. The Company reserves the right to dispose or otherwise deal with an abandoned product or part at its discretion.
9. This warranty does not apply if:
 - (i) the goods have not been paid for by the Buyer as per the credit terms provided; or
 - (ii) the goods have not been installed in accordance with AS NZS 3000/2000 Australian/New Zealand Wiring rules; or
 - (iii) the goods have been misused or neglected.
10. The Company assumes no responsibility under this warranty for the labour costs involved in the removal of defective parts, installation of new parts or service charges related thereto.
11. If a fault covered by this warranty occurs, the Buyer must first contact the Company at the contact address listed below.
12. Any warranty claim must be accompanied by:
 - (i) proof of purchase;
 - (ii) written details of the alleged defect; and
 - (iii) appropriate documentation (such as installation and maintenance records etc).
13. The Company shall have the option of requiring the return of the defective part (transportation prepaid by the Buyer) to establish the claim.
14. The Company makes no warranties or representations other than set out in this clause 7.
15. The repair or exchange of the goods or part of the goods, is the absolute limit of the Company's liability under this express warranty.

	Fantech Contacts	
	Head Office Victoria - Melbourne A.B.N. 11 005 434 024 Ph: +61 (3) 9554 7845 Fax: +61 (3) 9554 7833	New Zealand Auckland H.O. (09) 444 6266 Christchurch (03) 379 8622 Wellington (04) 566 0532
Australia Adelaide (08) 8294 0530 Brisbane (07) 3299 9888 Darwin (08) 8947 0447 Melbourne H.O. (03) 9554 7845 Perth (08) 9209 4999 Sydney (02) 8811 0400	Asia For agents in the Asian region call (603) 7846 0340 or visit www.eltafantechasia.com	www.fantech.com.au