



# HVLS Fan Air Movement Guide



The **Hunter** range of innovative, direct-drive HVLS fans use a unique aerofoil blade design with twist profile that maximises efficiency across the entire range of fan diameters. The advanced blade design delivers a higher volumetric flow rate whilst minimising power consumption. Its high performance direct drive motor helps minimise energy usage and reduces the overall weight.



**FANTECH**  
Intelligent Ventilation



Conditions apply\*

# Permanent Magnet Motor Efficiency

HVLS fans from Hunter use 3-phase direct drive, permanent magnet motors that come with several advantages:

- Generates large amounts of torque while operating at slow speeds
- Whisper quiet gearless operation at less than 55dBA @ 3metres
- Offers significant savings on running costs and efficient performance under partial loads
- Up to 25% more energy efficient than gearbox or gear driven fan motor
- Extremely durable with fewer components
- Comes with a pre-configured VSD with simple push and turn plugs to connect to motor and touch screen



# Features and Benefits

## Next Generation Direct Drive Motor

Utilises a high-performance direct drive, permanent magnet motor to increase energy efficiency and reduce fan weight. It generates large amounts of torque at slow speeds while providing whisper-quiet gearless operation.

## Cutting Edge Blade Technology

Hunter's structural grade aluminium blades maximise air flow and minimise noise levels with a unique twist profile to match each individual fan size.

## Effortless Installation

Time-saving plug-n-play system includes pre-installed bolts, pre-wired downrod, pre-aligned mounting brackets and I-beam clamp.

## Contemporary Style

Built tough with a sleek design that will complement any showroom, sports centre or warehouse.

## Five Fan Ranges

### HVLS

- Hunter Titan - 5 sizes from 4.2 (14') to 7.3 (24') metres
- Hunter ECO - 8 sizes from 2.4 (8') to 7.3 (24') metres
- Hunter RM - 4 sizes from 2.4 (8') to 4.2 (14') metres

### Sweep

- Hunter Trak - 4 sizes from 1.5 (5') to 2.4 (8') metres
- Stingray Sweep Fans - 1 size 1.5 metres (5')



HVLS FANS

# Hunter Titan

## HVLS Fan

There are large industrial HVLS fans, and there's the Titan. Available in five sizes from 4.2m to 7.3m this master of the air thoroughly mixes the air within an indoor space eliminating uneven temperatures. It can reduce energy costs, improve comfort and increase productivity. The Titan features an efficient direct drive permanent magnet motor designed to be quieter, generate large amounts of torque and is up to 25% more efficient than gear driven HVLS fans. These Hunter HVLS fans not only provide widespread air movement, they also have a sleek and contemporary design that will complement any commercial space.

- Blades are formed with a unique twist profile for each individual fan size to maximise air flow and minimise noise levels
- Simplifies installation with pre-installed bolts, quick connect blades, pre-wired drop tube, pre-aligned mounting brackets and I-beam clamp
- Effective coverage area, ranging from 484m<sup>2</sup> (4.2m Titan HVLS) to 1,369m<sup>2</sup> (7.3m Titan HVLS)
- Adjustable downrods options from 0.76 to 3.05 metres drop
- Highly efficient 5 blade configuration designed to maximise air flow performance
- A range of proprietary controllers are available to manage from 1 to 30 fans. See page 10 for more information on the controller range
- Can be connected to a Building Management System (BMS)
- Comes standard with a 350 series fan controller



*Each blade on the Titan HVLS fan snap-locks into the direct drive motor hub and is secured via 2 fixing screws*



Conditions apply\*

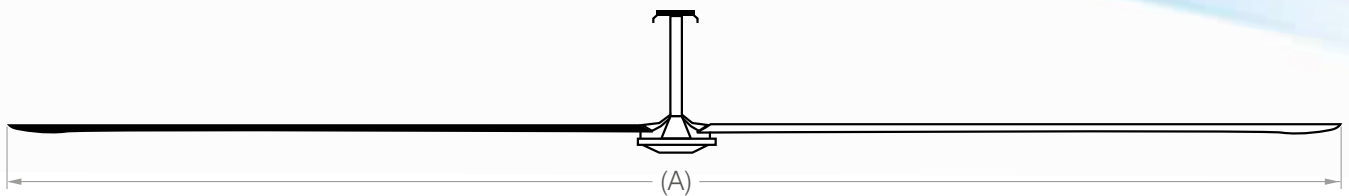

## Technical Data

Model No.	HUNTER-TITAN14	HUNTER-TITAN16	HUNTER-TITAN18	HUNTER-TITAN20	HUNTER-TITAN24
<b>Fan Diameter (A)</b>	4.2m	4.8m	5.5m	6.1m	7.3m
<b>Input Power</b>	AC 3PH 380-480V 50/60 Hz				
<b>Full Load Amps</b>	3 Amps	3 Amps	3 Amps	3 Amps	3 Amps
<b>Motor Power</b>	3/4 HP	1 HP	1 HP	1 HP	1 HP
	0.72 kW	1.01 kW	1.47 kW	1.02 kW	1.22 kW
<b>Effective Range Area**</b>	719 m <sup>2</sup>	929 m <sup>2</sup>	1186 m <sup>2</sup>	1452 m <sup>2</sup>	2090 m <sup>2</sup>
<b>Max air flow AMCA230-23</b>	40.78 m <sup>3</sup> /s	61.09 m <sup>3</sup> /s	68.56 m <sup>3</sup> /s	76.64 m <sup>3</sup> /s	105.44 m <sup>3</sup> /s
<b>Max RPM</b>	103	95	93	73	64
<b>Fan Hang Weight#</b>	76 kg	79 kg	83 kg	86 kg	93 kg

\*\* Effective range area is based on 1.5 to 2 m/s air flow at face/chest level

# Total fan hang weight. Included blades, motor, hanging system, accessories  
Adjustable downrod options available from 0.76 to 3.04 metres

# Hunter ECO

## HVLS Fan

Hunter ECO is one of the lightest HVLS fans available with robust direct drive motor and structural aluminium blade design. The range also comes with the same plug & play, pre-assembled technology to simplify installation and a choice of touchscreen controllers to manage a network of up to 30 HVLS fans.

With blade spans from 2.4m to 7.3m, the Hunter ECO range of HVLS fans will de-stratify your building space and reduce your energy bill while making your workforce comfortable and more productive.

- Blades are formed with a unique twist profile for each individual fan size to maximise air flow and minimise noise levels
- Simplifies installation with pre-installed bolts, quick connect blades, pre-wired downrod, pre-aligned mounting brackets and I-beam clamp
- Adjustable downrods options from 0.76 to 3.05 metres drop
- Effective coverage area, ranging from 95m<sup>2</sup> (2.4m ECO HVLS) to 858m<sup>2</sup> (7.3m ECO HVLS)
- Highly efficient 4 blade configuration designed to maximise air flow performance
- A range of proprietary controllers are available to manage from 1 to 30 fans. See page 10 for more information on the controller range.
- Can be connected to a Building Management System (BMS)
- Comes standard with a 350 series fan controller

Each blade on the ECO HVLS fan is bolted to the direct drive motor hub via pre-installed studs



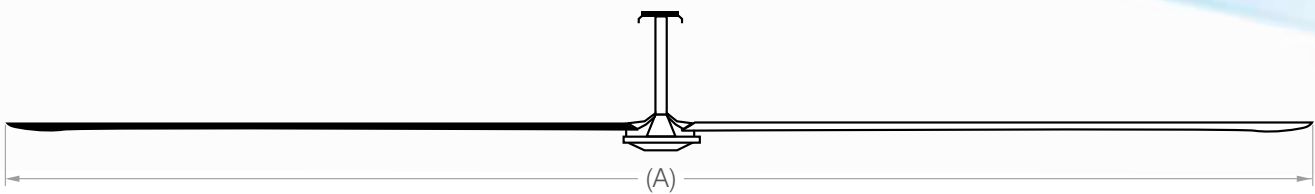

## Technical Data

Model No.	HUNTER-ECO08	HUNTER-ECO10	HUNTER-ECO12	HUNTER-ECO14	HUNTER-ECO16	HUNTER-ECO18	HUNTER-ECO20	HUNTER-ECO24
<b>Fan Diameter(A)</b>	2.4m	3.0m	3.6m	4.2m	4.8m	5.5m	6.1m	7.3m
<b>Input Power</b>	AC 3PH 380-480V 50/60 Hz							
<b>Full Load Amps</b>	2 Amps	3 Amps	3 Amps	3 Amps	3 Amps	3 Amps	3 Amps	3 Amps
<b>Motor Power</b>	5/8 HP	5/8 HP	5/8 HP	5/8 HP	5/8 HP	5/8 HP	5/8 HP	5/8 HP
	0.89 kW	0.75 kW	0.78 kW	0.71 kW	1.01 kW	0.85 kW	0.92 kW	1.12 kW
<b>Effective Range Area**</b>	149 m <sup>2</sup>	232 m <sup>2</sup>	334 m <sup>2</sup>	455 m <sup>2</sup>	595 m <sup>2</sup>	753 m <sup>2</sup>	929 m <sup>2</sup>	1338 m <sup>2</sup>
<b>Max air flow AMCA230-23</b>	15.41 m <sup>3</sup> /s	25.02 m <sup>3</sup> /s	30.38 m <sup>3</sup> /s	40.69 m <sup>3</sup> /s	51.40 m <sup>3</sup> /s	60.27 m <sup>3</sup> /s	72.17 m <sup>3</sup> /s	96.48 m <sup>3</sup> /s
<b>Max RPM</b>	156	139	108	108	94	80	77	62
<b>Fan Hang Weight#</b>	39 kg	43 kg	46 kg	58 kg	61 kg	63 kg	66 kg	72 kg

\*\* Effective range area is based on 1.5 to 2 m/s air flow at face/chest level

# Total fan hang weight. Included blades, motor, hanging system, accessories  
Adjustable downrod options available from 0.76 to 3.04 metres



HVLS FANS

# Hunter **RM** HVLS Fan

The Hunter RM series High Volume, Low Speed (HVLS) is specially designed for hassle-free and cost saving installations. Engineered with a direct drive motor and single phase input, the RM comes with a pre-wired downrod that uses a self-levelling and a quick connect mounting system.

Hunter RM series HVLS fans are available in 4 sizes; 2400 mm, 3000 mm, 3600 mm and 4200 mm diameter. They are well suited to large indoor facilities where generating air movement is essential for improving comfort, such as warehouses, factories, workshops, gymnasiums and public recreation facilities.

- Energy efficient and compact, single phase direct drive permanent magnet motor
- Blades are formed with a unique twist profile for each individually fan size to maximise air flow and minimise noise levels
- Time saving plug-n-play system with pre-installed bolts and mounting plate
- Rigid downrod options from 0.61 to 1.21 metres drop
- Highly efficient 4 blade configuration
- Comes with a pre-configured proprietary VSD
- A range of proprietary controllers are available to manage from 1 to 30 fans. See page 10 for more information on the controller range
- Can be connected to a Building Management System (BMS)
- Comes standard with a 350 series fan controller

*Comes with an all-in-one rigid down rod that simplifies installation and doesn't need guide wires*



*Conditions apply\**

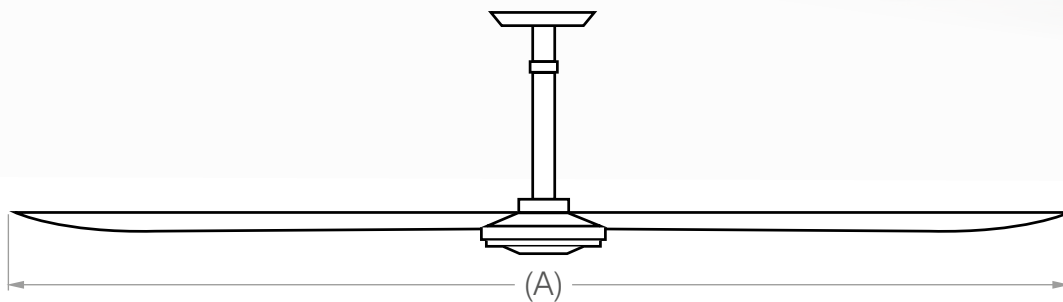

## Technical Data

Model No.	HUNTER-RM08-1PH	HUNTER-RM10-1PH	HUNTER-RM12-1PH	HUNTER-RM14-1PH
<b>Fan Diameter(A)</b>	2.4m	3.0m	3.6m	4.2m
<b>Input Power</b>	AC 1PH 240V 50/60 Hz			
<b>Full Load Amps</b>	6.5 Amps	6.5 Amps	6.5 Amps	6.5 Amps
<b>Motor Power</b>	5/8 HP	5/8 HP	5/8 HP	5/8 HP
	0.49 kW	0.75 kW	0.78 kW	0.71 kW
<b>Effective Range Area**</b>	149 m <sup>2</sup>	232 m <sup>2</sup>	334 m <sup>2</sup>	455 m <sup>2</sup>
<b>Max air flow AMCA230-23</b>	15.41 m <sup>3</sup> /s	25.02 m <sup>3</sup> /s	30.38 m <sup>3</sup> /s	40.69 m <sup>3</sup> /s
<b>Max RPM</b>	156	139	108	108
<b>Fan Hang Weight#</b>	39 kg	43 kg	46 kg	58 kg

\*\* Effective range area is based on 1.5 to 2 m/s air flow at face/chest level

# Total fan hang weight. Included blades, motor, hanging system, accessories  
Downrods available in 61cm, 90 cm and 121cm sizes



# Controllers

These touchscreen controllers are used with the Hunter Titan, Eco and RM HVLS fans and designed to manage from one Hunter HVLS fan to a large system with multiple fans and sensors. The control system takes advantage of the latest digital technology to ensure it can be tailored to suit the requirements of almost any high ceiling application.

Optional BMS BACnet gateway modules are also available.

## 350 Series Touchscreen Fan Controller

- Controls up to 10 fans as one group
- Intuitive graphic user interface
- Fan diagnostics on screen
- Speed control in forward and reverse
- Comes standard with every Titan, ECO and RM industrial HVLS fan



## 500 Series Touchscreen Fan Controller

- Controls up to 30 fans
- Fan grouping, program scheduling fan and group naming, password protection
- Intuitive graphic user interface
- Fan diagnostics on screen
- Speed control in forward and reverse



## 700E Environmental Fan Network Controller

- Controls up to 30 fans
- Fan grouping, program scheduling fan and group naming, password protection
- Intuitive graphic user interface
- Fan diagnostics on screen
- Speed control in forward and reverse
- Includes two temperature & humidity sensors



## BMS Gateway

- Gateway to allow the fan network to communicate to the BMS and maintain a local HMI controller
- Two models: BACnet TCP-IP and BACnet MS-TP
- Connects up to 30 Hunter HVLS fans



# Engineered for Easy Installation

When Hunter's Titan and ECO HVLS fans were developed, ease of installation was a primary factor in its engineering. The result is a range of Hunter HVLS fans that are quick to install, simple to commission and reduce the risk of installation mistakes. Hunter fans have fewer blades, fewer moving parts, the range weighs less and everything that can be pre-assembled has been.

- Hunter HVLS fans come with pre-installed studs, a pre-wired downrod and pre-aligned mounting brackets
- Blade clamps are replaced with a proprietary quick connect blade system
- Downrod comes with a quick connect clamping system that attaches downrod to the building's I-beam without drilling holes

3 adjustable downrods pre-wired with power and safety cable. Incremental adjustments from 0.76 to 3.05 metres drop.



The top plate has an integrated universal joint for pitched roof alignment and its quick connect clamping system eliminates the need to drill holes in the I-beam.



Integrated mounting plate with downrod and pre-installed studs simplifies motor mounting.

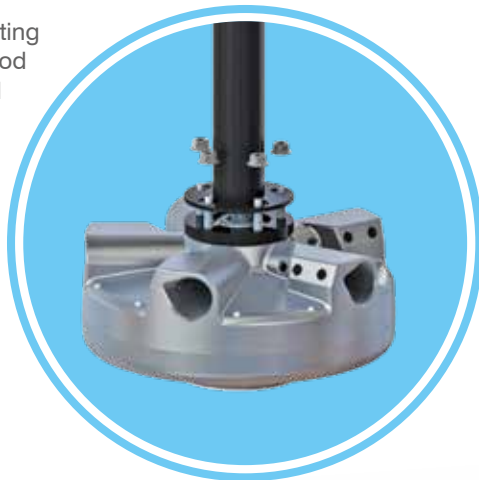

ECO Range: Each blade is bolted to the direct drive motor hub via pre-installed studs.



Easy to connect power and safety cable from the dropper tube to motor hub.



Titan Range: Each blade snap-locks into the direct drive motor hub and is secured via fixing screws.





Conditions apply\*

SWEEP FANS

# Hunter Trak

## Sweep Fan

The Hunter Trak sweep fan combines a balance of performance and modern design. Trak blends elegantly into its surroundings while providing the cooling effect and air flow that commercial spaces need. Its design includes a single phase direct drive motor and extruded aluminium blades that deliver optimal air flow for larger spaces.

The Trak is well suited to indoor commercial applications and also outdoor spaces such as restaurants, meeting areas, patios, fitness centres, and schools.

- Energy efficient, adjustable speed DC motor that can be operated in forward or reverse
- IP45 rated for use in outdoor undercover areas such as outdoor dining
- Time saving plug-n-play system with pre-installed components
- Comes standard with a 61 cm long life stainless steel downrod
- Optional downrods; 61 cm, 90 cm, 121 cm, 152 cm
- Highly efficient 4 blade configuration with an 18° blade pitch for optimal air movement
- Trak comes in matt black as standard. White or silver grey colours available as optional



- Wireless TRAK Controller**
- Control multiple fans up to 25m radius
  - Fan speeds
  - Light dimmer option



- Basic TRAK Network Controller#**
- Control up to 5 fans
  - CAT5E Ethernet
  - BACnet Gateway
- Model: HUNTER-WR-BASIC



- TS350 TRAK Network Controller#**
- Control up to 10 fans
  - CAT5E Ethernet
  - BACnet Gateway
- Model: HUNTER-WR-TS350



- TS400 TRAK Network Controller#**
- Control up to 30 fans
  - CAT5E Ethernet
  - BACnet Gateway
- Model: HUNTER-WR-TS400

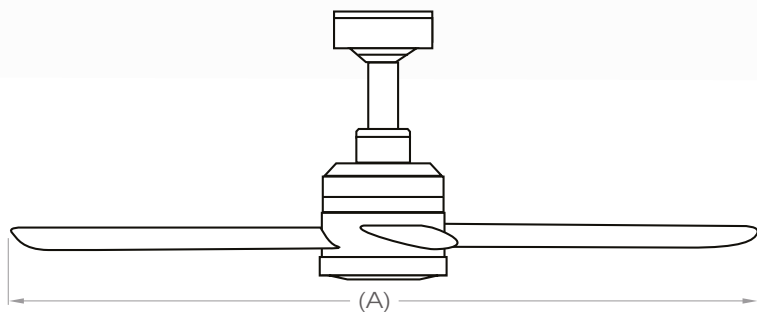
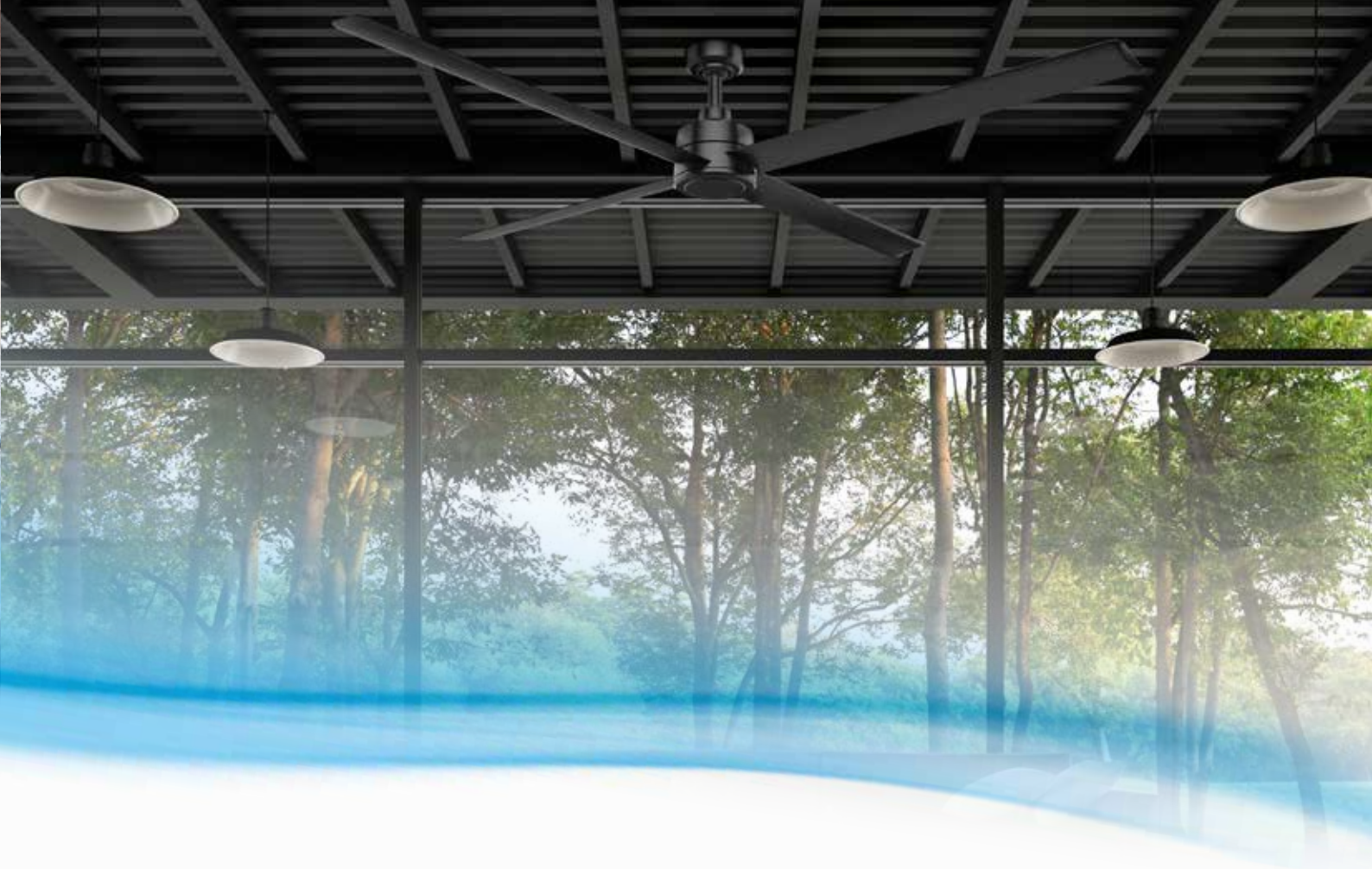

## Colour Options



White



Silver Grey



Matt Black

## Technical Data

Model No: (with wireless remote)	HUNTER-TRAK05	HUNTER-TRAK06	HUNTER-TRAK07	HUNTER-TRAK08
Model No: (wired with BACnet gateway)	HUNTER-TRAK05...WR	HUNTER-TRAK06...WR	HUNTER-TRAK07..WR	HUNTER-TRAK08...WR
Fan Diameter(A)	1.5m	1.8m	2.1m	2.4 m
Input Power	AC 1PH 240V 50/60 Hz			
Full Load Amps	0.65 Amps	0.78 Amps	0.75 Amps	0.78 Amps
Motor Power	0.13 HP	0.13 HP	0.13 HP	0.13 HP
	0.68 kW	0.76 kW	0.61 kW	1.37 kW
Effective Range Area**	37 m <sup>2</sup>	54 m <sup>2</sup>	73 m <sup>2</sup>	95 m <sup>2</sup>
Max air flow	6.15 m <sup>3</sup> /s	8.45 m <sup>3</sup> /s	10.44 m <sup>3</sup> /s	11.69 m <sup>3</sup> /s
Max RPM	192	162	139	143
Fan Hang Weight#	22 kg	22 kg	22 kg	22 kg

\*\* Effective range area is based on 1.5 to 2 m/s air flow at face/chest level

# Total fan hang weight. Included blades, motor, hanging system, accessories  
Downrod options available in 61cm, 90 cm, 121cm and 152 cm sizes



SWEEP FANS

# Hunter Stingray

## Sweep Fan

The Hunter Stingray sweep fan features a sleek, contemporary design that is well suited to indoor commercial applications and large open plan living spaces. With a 152cm span, its blade pitch is optimised for maximum efficiency and air movement. The Stingray comes with optional integrated LED light and features a charcoal grey or porcelain white finish.

- Reversible, quiet DC motor for optimal performance in summer and winter
- IP45 rated for use in outdoor undercover areas such as outdoor dining
- Comes with an 18-watt dimmable LED light that can be capped if not required (included in kit)
- Pre-balanced for smoother, low noise operation
- Remote control with 6 fan speeds and light dimmer
- Comes standard with a 5cm and 23cm downrod



Remote Control



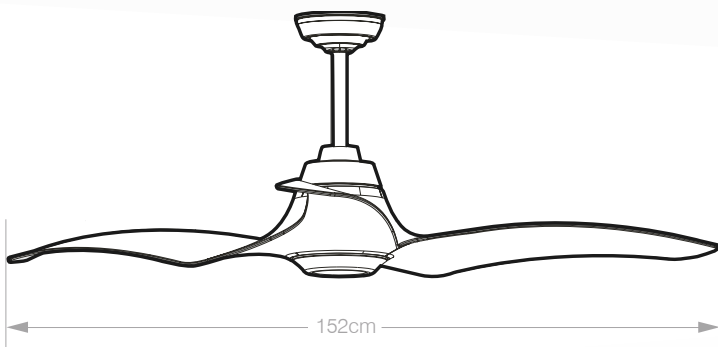

### Colour Options



Porcelain White



Charcoal Grey

### Technical Data

Model No.	HUNTER-SR60BK	HUNTER-SR60WH
Max Air flow	3.15 m <sup>3</sup> /s	
Max Watts	21	
Max RPM	167	
LED Light	1520 Lumens	
Fan Hang Weight	11 kg	

Comes standard with a 5cm and 23cm downrod



# Selecting the Correct HVLS Fan

Not all HVLS fans are the same. Whether you are moving air through a commercial space, temperature sensitive facility or large industrial warehouse, choosing the right size Hunter fans with the most effective spacing will give the best return on your customer's investment.

To assist with choosing the most effective Titan, ECO or RM HVLS fans, our web-based step by step application makes selection easy. Once on the HVLS page, simply enter the width, length, and height of the area, together with the ambient temperature and desired cooling effect from the fans. The selection tool will provide a number of possible options that list the number of fans, fan sizes and suggested spacing.

The Fantech HVLS selection tool performs calculations to ASHRAE 55-2017 "Thermal Environmental Conditions for Human Occupancy". This determines the cooling effect of Hunter Titan HVLS fans at different locations relative to the fans (under normal conditions). It can also estimate energy savings when using HVLS fans in air-conditioned spaces, or when HVLS fans are used for de-stratification.

▶ Visit our HVLS fan selection tool  
[www.fantech.com.au/hvls/](http://www.fantech.com.au/hvls/)



## Suggested wiring layout for Titan, ECO or RM HVLS fans

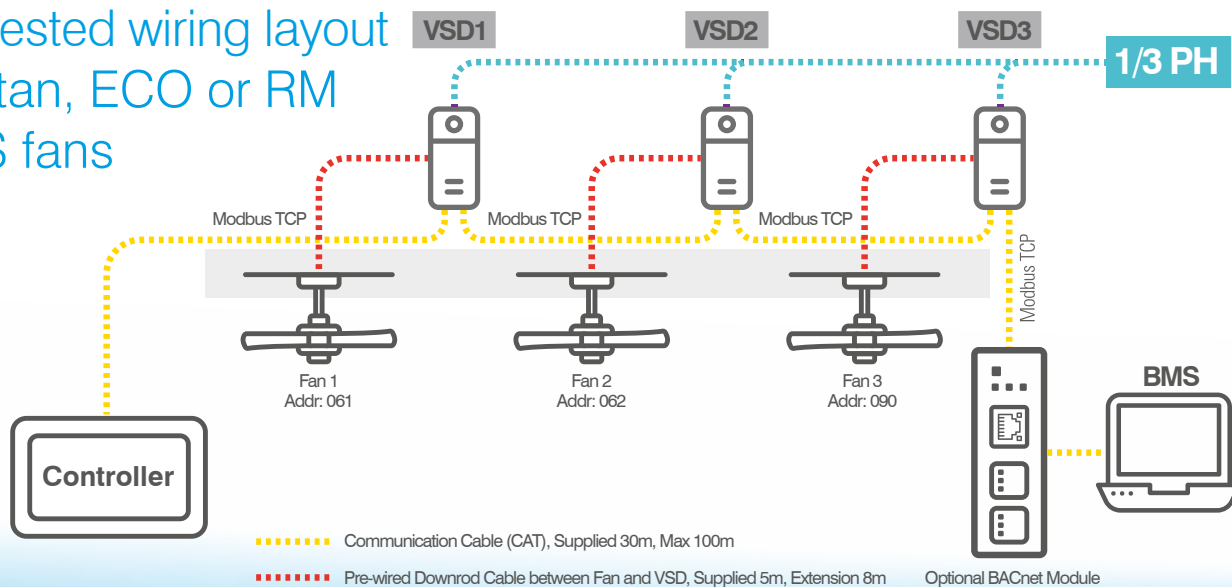

### Fantech Pty. Ltd.

Victoria: (+61 3) 9554 7845  
 New South Wales: (02) 8811 0400  
 South Australia: (08) 8294 0530  
 Northern Territory: (08) 8947 0447  
 Queensland: (07) 3299 9888  
 Western Australia: (08) 9209 4999  
 A.C.T.: (02) 6280 5511  
 New Zealand: (09) 444 6266

[www.fantech.com.au](http://www.fantech.com.au) |

For sales enquiries contact:

Specifications and design subject to change without notice.