

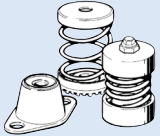

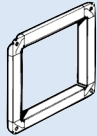

ANCILLARY EQUIPMENT

 Vibration Isolators <i>Ref. Section I</i>	 POW - Matching Flanges <i>Ref. Section J</i>	 FT - Mounting Foot <i>Ref. Section J</i>
 SD - Star/Delta switch <i>Ref. Section M</i>	 Variable speed drives <i>Ref. Section M</i>	 VA - Speed controller <i>Ref. Section M</i>

DESCRIPTION

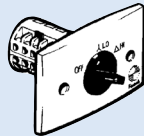
The PowerLine Series® of In-Line Centrifugal Fans is designed for a wide range of duct mounted applications. They are most suitable in commercial and industrial applications where medium to high air pressure is required. They are available in various speed options and 8 sizes, extending from 315 to 710mm diameter.

Typical Applications

Commercial and industrial supply or exhaust air applications such as shopping centres, office buildings, exhibition centres, hotels, health centres, schools and universities.

Features

- Robust, yet lightweight galvanised steel construction.
- Easy to fit 35mm TDF profile flange connections.
- Choice of external rotor or standard direct-drive TEFC motors.
- Large choice of speeds available.
- Most 3-phase external rotor motors fitted are 2-speed star/delta design.
- To improve energy efficiency, motors can be speed-controlled
- Motors complying with Ex d, Ex e, Ex nA and Ex tD Standards can be fitted.
- Can be mounted in any position.
- A range of matched ancillaries is also available.

Construction

Galvanised steel housings with 35mm TDF profile flange connections.

Backward-curved centrifugal impellers. DD impellers are made from aluminium, ER impellers made from high performance injection moulded composite plastic.

Motors

Type - can be supplied with direct-driven external rotor or standard direct-drive TEFC motors.

Electricity supply - single or three-phase to suit a wide range of voltages and frequencies.

Bearings - sealed-for-life, ball.

External rotor motors are fully speed-controllable using electronic or auto-transformer controllers, however Sinusoidal filters are required when a variable speed drive is used.

Standard direct-drive TEFC motors can be single or multi-speed and can be speed-controlled using a variable speed drive.

See pages O-2/3 for details on external rotor motors and pages O-3/4 for details on standard direct-drive TEFC motors.

If standard frame motors complying with Ex d, Ex e, Ex nA and Ex tD Standards are required, selection can be made from these pages.

Internal Thermal Protection

Automatic-reset type is fitted as standard to external rotor motors and is an optional extra on standard frame motors.

Testing

Air flow tests to ISO5801:2007

Noise tests to BS848:Part 2, 1985

Wiring Diagram

See pages N-8, diagrams ER1, 2, 3, 4, 5 for external rotor motors and N-6/7, diagrams DD1, 2, 3, 7, 9 for standard direct-drive TEFC motors.

SUGGESTED SPECIFICATION

The duct mounted fans shall be of the In-line Centrifugal PowerLine® Series as designed and manufactured by Fantech Pty Ltd and be of the model numbers shown on the schedule/drawings.

They shall include galvanised steel housings with 35mm TDF profile flange connections.

The backward-curved centrifugal impellers shall be driven by external rotor or standard direct-drive TEFC motors as nominated.

All models shall be fully tested as a complete assembled unit to ISO5801: 2007 for air flow and BS848:Part 2, 1985 for noise.

HOW TO ORDER

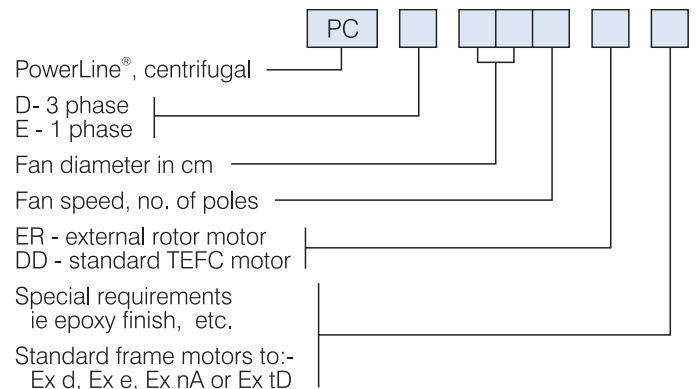

Note

Performance curves shown are based on nominal speeds.

As motor speeds may vary from one manufacturer to another, and from one motor type to another, it is possible actual fan speeds may differ and, therefore, the performance of the fan.

For external rotor motor performance refer to Fans by Fantech Selection Program

DIMENSIONS

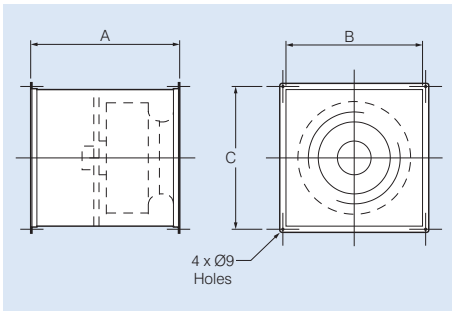

Model	Dimensions, mm				App. wt.
PCE..	A*	A**	B□	C□	kg#
31.	500	400	400	433	36
35.	550	425	450	483	40
40.	550	450	500	533	42
45.	600	475	550	583	54
50.	700	500	650	683	67
56.	800	550	725	758	95
63.	850	550	800	833	117
71.	900	600	900	933	132

* Fan with direct-drive motor - DD
 ** Fan with external rotor motor - ER
 # Weight for fan with direct-drive motor only

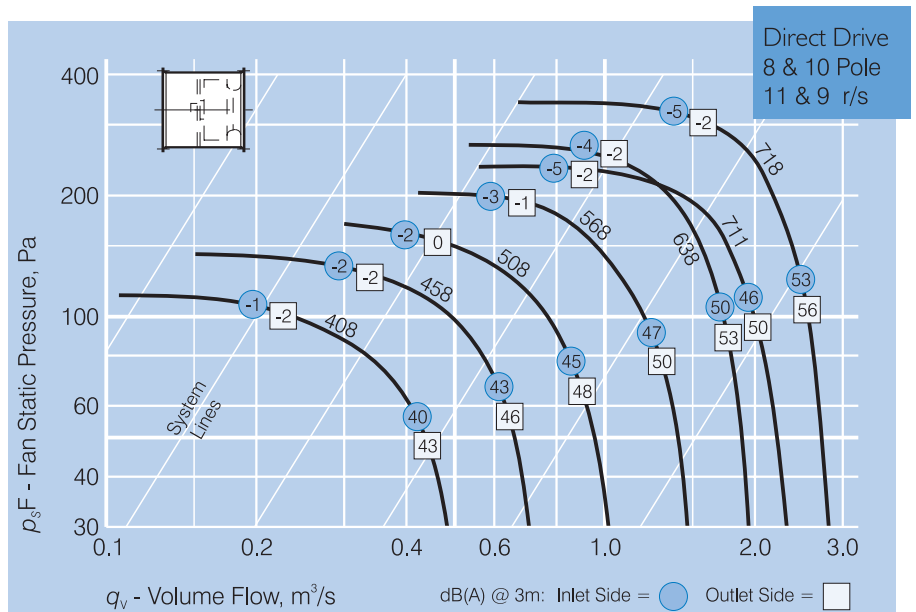
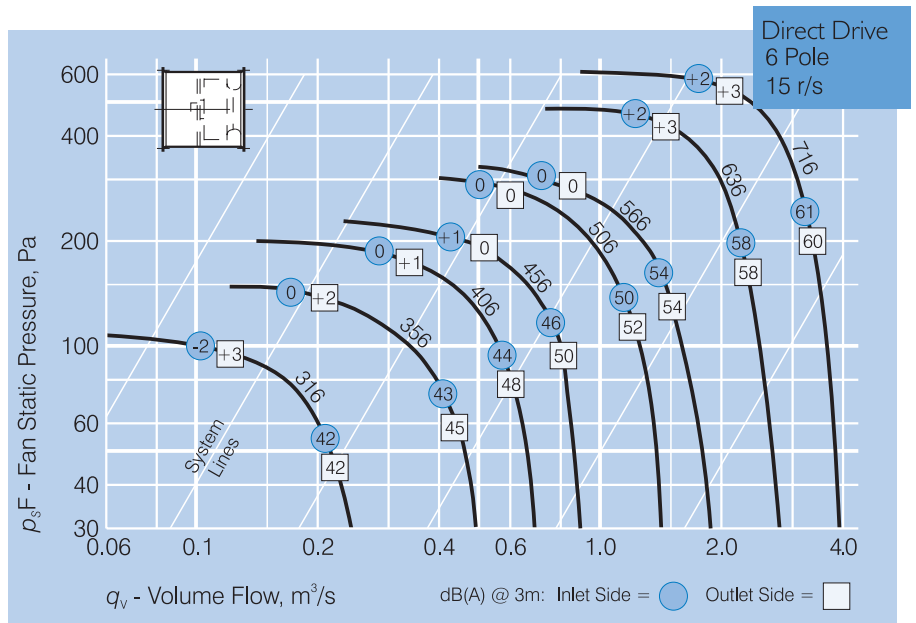
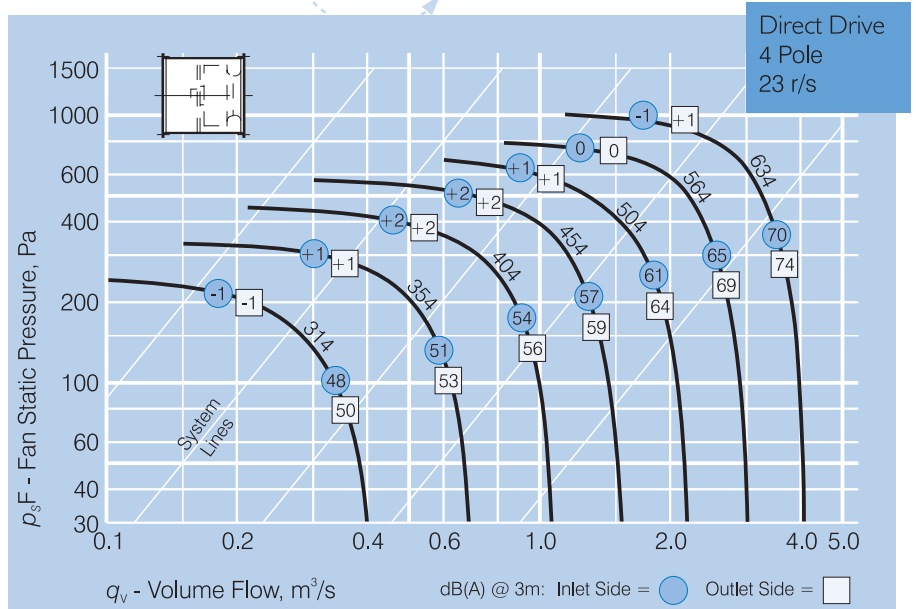

TECHNICAL DATA & NOISE LEVELS

Model	Nom. PCD.. PCE..	speed, rev/sec	PCE/D..DD Avg. dB(A) @ 3m		PCE..ER. 1 ph.		PCD..ER. 3 ph.		PCE/D..DD 1 ph. 3 ph.		In-Duct Spectrum Corrections, dB**							
			Low Flow	High Flow	kW	Amps	kW	Amps	kW*	kW*	63	125	250	500	1k	2k	4k	8k
314	23	Inlet	47	48	0.14	0.62	0.14	0.29	0.25	0.37	35	29	21	18	10	10	8	2
		Outlet	49	50							31	25	19	19	14	12	7	0
316	15	Inlet	40	42	0.08	0.57†	0.10	0.16	-	0.37	34	26	22	18	12	12	6	0
		Outlet	45	42							31	27	18	18	16	11	7	3
354	23	Inlet	52	51	0.27	1.30	0.24	0.47	0.25	0.37	28	26	22	19	10	12	11	1
		Outlet	54	53							24	27	16	17	16	14	8	1
356	15	Inlet	43	43	0.11	0.49	0.16	0.27	-	0.37	33	25	22	19	14	8	3	0
		Outlet	47	45							31	27	18	18	16	11	7	3
404	23	Inlet	56	54	0.43	1.90	0.44	0.77	0.55	0.37	28	26	21	18	11	12	12	5
		Outlet	58	56							26	26	17	17	16	13	10	6
406	15	Inlet	44	44	0.17	0.83	0.16	0.40	-	0.37	33	28	22	19	14	10	7	3
		Outlet	49	48							27	24	17	17	15	12	9	1
408	11	Inlet	39	40	-	-	0.10	0.21	-	-	33	26	19	16	14	14	12	3
		Outlet	41	43							30	23	16	15	16	15	11	1
454	21	Inlet	59	57	0.77	3.60	0.65	1.30	0.75	0.75	27	25	20	17	11	12	12	8
		Outlet	61	59							28	24	17	17	16	12	11	10
456	15	Inlet	47	46	0.30	1.40	0.25	0.58	-	0.37	31	30	21	18	13	11	9	5
		Outlet	50	50							24	22	17	16	15	13	11	0
458	11	Inlet	41	43	-	-	0.14	0.30	-	-	33	26	19	16	14	14	12	3
		Outlet	44	46							30	23	16	15	16	15	11	1
504	23	Inlet	62	61	1.30	5.80	1.20	2.20	1.50	1.10	26	26	21	15	12	12	12	9
		Outlet	65	64							26	24	17	16	16	10	9	8
506	15	Inlet	50	50	0.48	2.40	0.42	0.93	-	0.37	30	29	22	16	12	10	8	6
		Outlet	52	52							27	25	18	17	16	13	11	2
508	11	Inlet	43	45	0.21	0.99	0.23	0.49	-	-	32	26	20	16	14	13	12	4
		Outlet	48	48							32	24	17	16	16	14	11	1
564	23	Inlet	65	65	-	-	1.70	3.30	-	2.20	26	27	23	14	13	12	12	10
		Outlet	69	69							25	25	17	16	17	8	8	7
566	15	Inlet	54	54	0.66	3.00	0.65	1.40	-	0.55	29	29	23	15	12	10	8	7
		Outlet	54	54							30	27	19	17	16	12	10	3
568	11	Inlet	44	47	0.35	1.65	0.44	0.80	-	-	30	27	22	15	15	11	11	6
		Outlet	49	50							33	24	18	17	16	13	10	1
634	23	Inlet	69	70	-	-	3.90	6.60	-	4.00	24	28	24	12	13	11	12	10
		Outlet	75	74							24	27	18	16	18	7	7	7
636	15	Inlet	60	58	-	-	0.65	1.15	-	1.10	28	29	24	14	12	10	8	8
		Outlet	61	58							32	28	19	17	15	11	8	4
638	11	Inlet	46	50	-	-	0.29	0.50	-	0.55	28	27	23	14	14	9	10	6
		Outlet	51	53							34	24	18	17	16	11	9	0
716	15	Inlet	63	61	-	-	2.10	4.10	-	2.20	28	29	24	14	12	10	8	8
		Outlet	63	60							32	28	19	17	15	11	8	4
718	11	Inlet	48	53	-	-	0.66	2.00	-	1.10	28	27	23	14	14	9	10	6
		Outlet	54	56							34	24	18	17	16	11	9	0
711	9	Inlet	41	46	-	-	0.28	1.20	-	-	28	27	23	14	14	9	10	6
		Outlet	48	50							34	24	18	17	16	11	9	0

Electrical data in **bold** type refers to fans fitted with 2-speed star/delta motors as standard.

* Amperages for standard TE motors can be obtained at time of order. Check fan nameplate for exact amperages of all motors.

** Add the In-Duct Spectrum Corrections to the appropriate dB(A) level to obtain the In-Duct Sound Power Level. Note: there are noise levels for both the Inlet and Outlet Sides of the Units.

† The PCE316ER unit is not speed controllable.